

Short communication. First detection of a phytoplasma infecting faba bean (*Vicia faba* L.) in Spain

S. Castro and J. Romero*

Departamento de Protección Vegetal. INIA. Ctra. Coruña, km 7.5. 28040 Madrid. Spain

Abstract

Faba bean is one of the most widely grown protein-producing food legumes. Faba bean plants showing symptoms of shoe stringed leaves, phyllody and flower abortion were observed in fields of Antequera (Málaga, Southern Spain). The etiology of this disease was investigated using graft transmission to periwinkle plants, polymerase chain reaction (PCR) with phytoplasma-specific primers, sequencing and phylogenetic analysis. We could not obtain amplification products from asymptomatic plants, whereas all tests were positive for phytoplasma infection from plants showing symptoms. Phylogenetic analysis indicated that this phytoplasma clustered in the 16SrIII group, the type member of which is X-disease phytoplasma. This is the first report of a phytoplasma infecting faba bean in Spain, and the first report of a phytoplasma in this group infecting faba bean.

Key words: legumes, X-disease phytoplasma group, 16S rDNA sequence, polymerase chain reaction, cloning phytoplasma DNA, phylogenetic analysis.

Resumen

Nota corta. Primera detección de un fitoplasma infectando haba (*Vicia faba* L.) en España

El haba es una leguminosa ampliamente cultivada como fuente de proteínas para la alimentación humana y animal. En campos de cultivo de habas en Antequera (provincia de Málaga, sur de España) se observaron plantas de haba con hojas filiformes, filodia y aborto de flores. La etiología de esta enfermedad fue estudiada mediante la transmisión por injerto a plantas indicadoras de fitoplasmas, amplificación por la reacción en cadena de la polimerasa (PCR) con cebadores específicos de fitoplasmas, secuenciación de los fragmentos amplificados y análisis filogenéticos. No se pudieron obtener productos de amplificación a partir de plantas asintomáticas, mientras que se obtuvieron resultados positivos de infección por fitoplasmas con todas las técnicas utilizadas a partir de plantas con síntomas. El análisis filogenético nos indicó que este fitoplasma se ubica en el grupo 16SrIII, cuyo miembro tipo es el fitoplasma de la enfermedad X. Este es el primer informe de la presencia de un fitoplasma infectando habas en España, y el primero de un fitoplasma de haba en este grupo.

Palabras clave: legumbres, grupo del fitoplasma de la enfermedad X, secuencia rDNA 16S, reacción en cadena de la polimerasa, DNA de fitoplasma clonado, análisis filogenético.

Faba bean (*Vicia faba* L.) is the most important grain legume crop in the Mediterranean Basin. The susceptibility of faba bean to diseases is a major yield-reduction factor world-wide. In Spain, faba bean production is concentrated in the Mediterranean region and, recently, new fields have been sown nearby to the food process industry. In these fields we observed diseases not present in the traditional crop area. In faba bean fields of Antequera (Málaga, Southeastern Spain) we observed stunted plants with shoe stringed leaves,

phyllody and aborted flowers (Fig. 1), a syndrome possibly produced by phytoplasmas. In this work, we report the detection of phytoplasma in faba bean plants by PCR amplification and its characterization by sequencing and phylogenetic analysis.

Fresh shoots from diseased faba bean plants were graft-transmitted to healthy periwinkle (*Catharanthus roseus* (L.) G. Don) as explained in Castro and Romero (2002). Periwinkle plants grafted with shoots from diseased faba bean showed visible yellowing symptoms one month after grafting. Isolates were subsequently maintained by subgrafting-inoculation on periwinkle in the greenhouse.

* Corresponding author: romero@inia.es
Received: 10-09-03; Accepted: 25-02-04.



Figure 1. Symptoms of shoe stringing leaves and flowers abort in faba bean plants infected by phytoplasmas.

DNA was extracted from fresh shoots of both diseased and asymptomatic faba bean and graft-inoculated periwinkle plants using phytoplasma enrichment (Ahrens and Seemüller, 1992) or small-scale procedures (Zhang *et al.*, 1998).

A nested PCR using the universal phytoplasma primer pairs R16F2n/R2 (Lee *et al.*, 1993) and fU5/rU3 (Lorenz *et al.*, 1995) for the first and second PCR, respectively, amplifying fragments of 1.4 Kb and 900 bp, respectively, was performed following the protocol described by Lorenz *et al.* (1995). PCR products were not obtained from asymptomatic plants from the field or the greenhouse.

PCR products amplified from faba bean and periwinkle plants were purified on Bioclean columns (Biotools S.A., Madrid, Spain) and cloned into the plasmid vector pGEM-T Easy (Promega, Madison, WI, USA). Ligation, transformation and selection of recombinant clones were carried out according to the manufacturer's recommended protocol (T-Vector Cloning Brochure, Promega, Madison, WI, USA). Recombinant plasmid DNA was isolated and purified from recombinant colonies and then digested with the restriction enzyme *Eco* RI. Full-length inserts were

identified by comparing the size of inserts with that of the PCR-amplified fragment. The DNA sequence of both strands of the cloned PCR products was then determined using dye terminator chemistry and a DNA automatic sequencer (Applied Biosystem model 377, Foster City, CA, USA). The first nucleotide of the sequence started at position 365 of the reference Western X disease phytoplasma sequence (L04682). The nucleotide sequence (875 nt) obtained from faba bean and periwinkle were identical and this was deposited in the GenBank database under accession number AJ557264.

The nucleotide sequence of the 875 bp fragment amplified from faba bean and periwinkle plants was compared with that of the same fragment of the member type of each phytoplasma group (Lee *et al.*, 1998). Sequences of phytoplasmas for comparison were obtained directly from the EMBL GenBank database. Clustal W (Thompson *et al.*, 1994) was used for multiple alignments of sequences. Genetic distances among nucleotide sequences were calculated and corrected for multiple substitutions by Kimura's two-parameters method (Kimura, 1983). A phylogenetic tree was constructed by the neighbor-joining method (Saitou and Nei, 1987), its reliability was assessed by bootstrapping with 1000 replications (Efron, 1982) and visualized with the Treeview program (Page, 1996).

The topology of the tree was in agreement with that of previous reports (Gundersen *et al.*, 1994; Seemüller *et al.*, 1994; Lee *et al.*, 1998), indicating the equivalence of our approach with those generally accepted. The Spanish faba bean sample clusters, with high confidence, with the 16S rIII group (Fig 2). A different tree prepared with only phytoplasma members of group 16S rIII showed that a group adscription placed our sample close to Chayote witches' broom phytoplasma (Fig 3).

The symptoms found in faba bean plants did not resemble those produced by virus or fungal diseases and no phytoplasmas had been previously reported on faba bean in Spain. Our results with graft transmission to periwinkle plants of faba bean showing symptoms, amplification by PCR from both faba bean and periwinkle-grafted plants and similar characterization of amplified products, confirmed that the symptoms found in faba bean fields from Antequera were caused by a phytoplasma. Several authors have used RFLP analysis of PCR-amplified 16S rDNA sequences with a number of restriction enzymes to differentiate phytoplasmas on the basis of distinct RFLP patterns

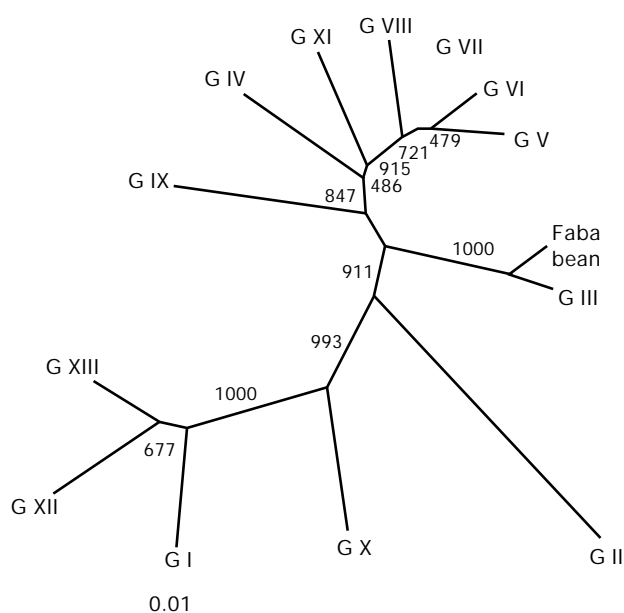

Figure 2. Phylogenetic tree constructed by the neighbour-joining method of 16S rRNA gene sequences from 13 phytoplasmas, representing RFLP groups according to Lee *et al.* (1998) and the faba bean phytoplasma. Numbers on branches are bootstrap values. Phytoplasmas representative of different groups were: G I, aster yellows (Accession AF268406); G II, Peanut witches'-broom (L33765); G III, western X-disease (L04682); G IV, coconut lethal yellowing (U18747); G V, elm yellows (AF122910); G VI, clover proliferation (AF409069); G VII, ash yellows (AF189215); G VIII, Loofah witches'-broom (AF248956); G IX, Caribbean PPWB mycoplasma (U18763); G X, apple-proliferation (X68375); G XI, rice yellow dwarf (D12581); G XII, stolbur (AF248959); G XIII, Mexican periwinkle virescence (AF248960); Faba bean phytoplasma from Spain (AJ557264).

(Schneider *et al.*, 1993). The only faba bean phytoplasma causing phyllody symptoms was described in the Sudan (Dafalla and Cousin, 1988), and was classified by RFLPs in the 16SrII (C) group (Saeed and Cousin, 1995; Lee *et al.*, 1998) or in the faba bean phyllody (FBP) group (Schneider *et al.*, 1995; Seemüller *et al.*, 1998). In the present case, using sequence and phylogenetic analysis, the Spanish faba bean phytoplasma was found to be taxonomically related to group III, where the member type is X-disease phytoplasma (Gundersen *et al.*, 1994). This is the first report of a phytoplasma infecting faba beans in Spain and the first of a faba bean phytoplasma in this group. The results, using 16S rRNA gene analysis, confirmed numerous preceding reports that different phytoplasmas may infect the same plant species. The identification of a vector or the study of other DNA regions of the phytoplasma genome, such as ribosomal protein gene or

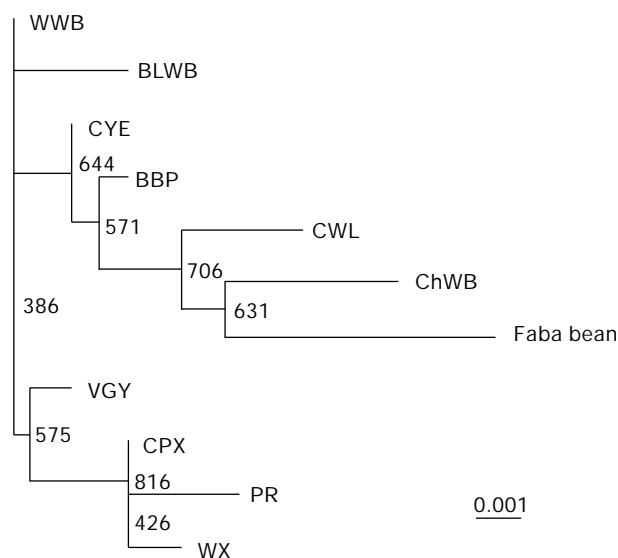

Figure 3. Phylogenetic tree constructed by the neighbour-joining method of 16S rRNA gene sequences from phytoplasmas, representing RFLP group III according to Lee *et al.* (1998) and the faba bean phytoplasma. Numbers on branches are bootstrap values. Phytoplasmas in group III were: BBP, blueberry proliferation (AY034090); BLWB, black locust witches'-broom (AF244363); ChWB, chayote witches'-broom (AF147707); CPX, Canadian peach X (L33733); CWL, cirsim white leaf (AF373106); CYE, clover yellow edge (AF189288); PR, peach rosette (AF236121); VGY, Virginia grapevine yellows (AF060875); WWB, walnut witches'-broom (AF190227); WX, western X (AF533231); faba bean phytoplasma from Spain (AJ557264).

other random-cloned DNA fragments, would help to more finely characterize the Spanish faba bean phytoplasma.

Acknowledgments

We thank Dr. José M. Malpica for his help with phylogenetic analysis, Dr. Antonio Molina for comments and discussions and Francisco Sánchez for his technical assistance. This work was supported by grants RTA01-049 and AGL2001-0330 from Spanish Interministerial Commission for Science and Technology (CICYT).

References

- AHRENS U., SEEMÜLLER E., 1992. Detection of DNA of plant pathogenic mycoplasma-like organisms by a polymerase chain reaction that amplifies a sequence of the 16S rRNA gene. *Phytopathology* 82, 828-832.

- CASTRO S., ROMERO J., 2002. The association of clover proliferation phytoplasma with stolbur disease of pepper in Spain. *J Phytopathol* 150, 25-29.
- DAFFALLA G.A., COUSIN M.T., 1988. Phyllody of faba bean in the Sudan: Progress of symptom expression, host range and transmission to *Catharanthus roseus* through dodder. *Agronomie* 8, 441-449.
- EFRON B., 1982. The jackknife, the bootstrap and other resampling plans. SIAM, Philadelphia, PA, USA.
- GUNDERSEN D.E., LEE I.M., REHNER S.A., DAVIS R.E., KINGSBURY D.T., 1994. Phylogeny of mycoplasma-like organisms (phytoplasmas): A basis for their classification. *J Bacteriol* 176, 5244-5254.
- KIMURA M., 1983. The neutral theory of molecular evolution. Cambridge University Press. Cambridge, UK.
- LEE I.M., HAMMOND W., DAVIS R.E., GUNDERSEN D.E., 1993. Universal amplification and analysis of pathogen 16S rDNA for classification and identification of mycoplasma-like organisms. *Phytopathology* 83, 834-842.
- LEE I., GUNDERSEN-RINDAL D., BERTACCINI A., 1998. Phytoplasma: ecology and genetic diversity. *Phytopathology* 88, 1359-1366.
- LORENZ K., SCHNEIDER B., AHRENS U., SEEMÜLLER E., 1995. Detection of the apple proliferation and pear decline phytoplasmas by PCR amplification of ribosomal and nonribosomal DNA. *Phytopathology* 85, 771-776.
- PAGE R.D.M., 1996. TREEVIEW: An application to display phylogenetic trees on personal computers. *Computer Applications in the Biosciences* 12, 357-358.
- SAITOU N., NEI M., 1987. The neighbour-joining method: a new method for reconstructing phylogenetic trees. *Mol Biol Evol* 4, 406-425.
- SAEED E.M., COUSIN M.T., 1995. The genetic relationship between mycoplasma-like organisms causing diseases in the Sudan and different continents revealed by polymerase chain reaction (PCR) amplification of the 16S rRNA gene followed by restriction fragment length polymorphism analysis. *J Phytopathol* 143, 17-20.
- SCHNEIDER B., AHRENS U., KIRKPATRICK B.C., SEEMÜLLER E., 1993. Classification of plant-pathogenic mycoplasma-like organisms using restriction-site analysis of PCR-amplified 16S rDNA. *J Gen Microbiol* 139, 519-527.
- SCHNEIDER B., COUSIN M.T., KLINGKONG S., SEEMÜLLER E., 1995. Taxonomic relatedness and phylogenetic positions of phytoplasmas associated with diseases of faba bean, sunhemp, sesame, soybean and eggplant. *Z Pflanzenk Pflanzen* 102, 225-232.
- SEEMÜLLER E., SCHNEIDER B., MAURER R., AHRENS U., DAIRE X., KISON H., LORENZ K., FIRRAO G., AVINENT L., SEARS B., STACKEBRANDT E., 1994. Phylogenetic classification of phytopathogenic mollicutes by sequence analysis of 16 S ribosomal DNA. *Int J Syst Bacteriol* 44,440-446.
- SEEMÜLLER E., MARCONE C., LAUER U., RAGOZZINO A., GÖSCHL M. 1998. Current status of molecular classification of the phytoplasmas. *J Plant Pathol* 80, 3-26.
- THOMPSON J.D., HOGGINS D.G., GIBSON T.J., 1994. Clustal W: Improving the sensitivity of progressive multiple sequence alignment through sequence weighting, position-specific gap penalties and weight matrix choice. *Nucleic Acids Res* 26, 4673-4680.
- ZHANG Y.P., UYEMOTO J.K., KIRKPATRICK B.C., 1998. A small-scale procedure for extracting nucleic acids from woody plants infected with various phytopathogens for PCR assay. *J Virol Methods* 71, 45-50.